

Off ground measurement option for oszilloscopes, stripchart writers and Computers

- Save measurement in high- power circuits
- Differential input - change phase by swapping inputs
- Signal measurement on high potential
- Protection against induction spikes
- Input voltage range of 800Vpk to ground and 1500V differential
- Ideal for measurements in three phase high power networks



- Battery and/or charger operation

Description:

Surely you have encountered the necessity to remove the protective ground when making measurements of the current or of high voltages to perform the measuring at all.

Let alone that this procedure is against all safety rules, the casing might be under high voltage.

The operation of this measuring instrument is highly dangerous.

Or: One wants to measure several high voltages on a thyristor control with a two- or multiple-channel oscilloscope at once (phase comparison).

In the 500V/cm range the peak to peak amplitude of a 3-phase 400V mains is only about 2 divisions.

If used with Computers the corresponding output of 500V is 0,1V or 1V depending on the output range.

The output range is defined by an internal Jumper.

In this case measuring with grounded inputs is not possible at all. The solution to this problem: groundless measuring with the DA 1000 VN.

The unit can be powered by battery and/or Mains for 24hour operation as well.

The device is almost indestructible.

OPERATION:

Input: Via banana jacks which are appropriate for all 4mm banana plugs.

Safety banana plugs with contact protection are recommended.



The red plug is the non-inverting input, the blue one the inverting.

Front view

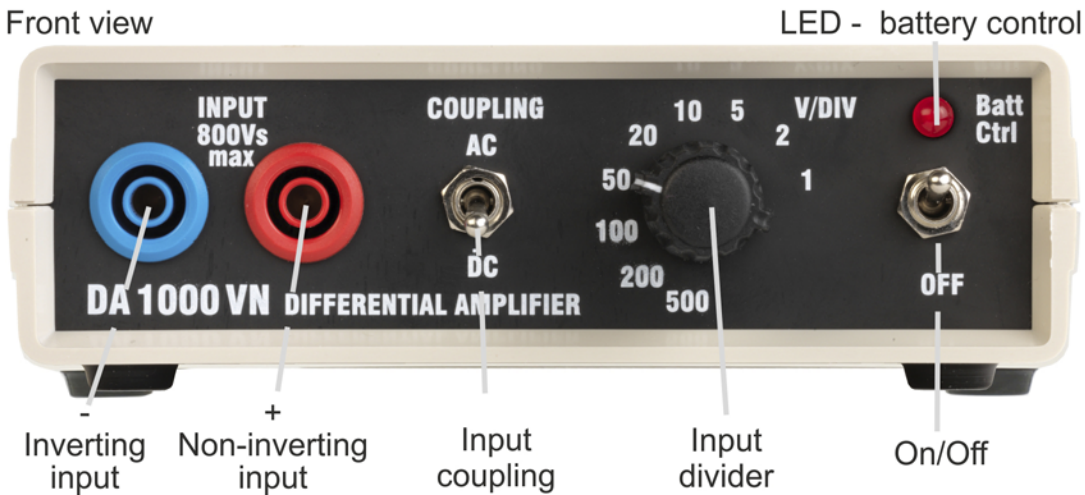

Input divider: It covers the range of 500V/div – 1V/div in the usual 1-2-5 sequence

Input coupling: AC/DC (alternating or direct current coupling)

AC low end bandwidth = 3Hz

Switching on and battery check:

Battery charger not connected:

After switching on the device the LED-lamp will light up for a short period indicating a intact battery.

Battery charger connected:

If the device is on, the LED will light up permanently. If it is off, it is only half as much.

Charging of NiMh accumulator in the device:

For charging the internal 9V battery any isolated adapter with a 12VDC power jack with 2mm (0.08") pin may be used. The voltage must be either in the range of 12-24VDC or 9-18VAC. The charging period – depending on the state of the battery – may take up to 6 hours.

Output: Via the BNC-connector on the rear side of the device.

The DA 1000 VN is connected to the measuring instrument via the BNC-cable and its input is set to 100mV/Div (default value).

In this position the input divider of the DA 1000 VN is calibrated.

Rear view

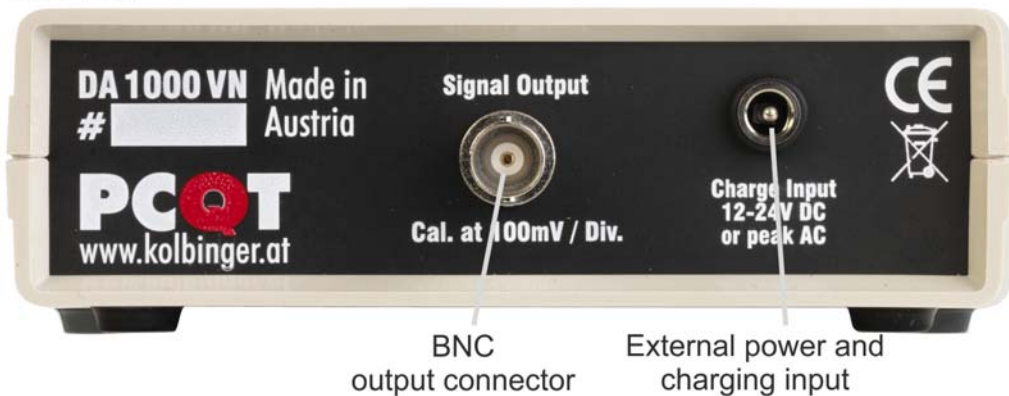

If another output calibration - 1V/div - is needed, it can be changed by a internal jumper.

The corresponding jumper is located inside the device between the instrumentation module and the circuit board containing the rotary switch. (See parts chart/circuit board assembly).

Jumper 2-3 (default): 100mV/div or 1Volt (+/-500mV) full scale

Jumper 1-2 : 1V/div or 10 volt (+/-5V) full scale

Before opening the device all input and output connections should be removed for safety reasons.

FUNCTIONAL DESCRIPTION:

The DA 1000 VN consists of a high impedance voltage divider (2x4M Ω) to which an instrumentation amplifier module with low noise and low power consumption is connected. For safety reasons the voltage divider series resistor consists of 2 x 4 precision resistors.

Power supply: The device is powered by a 9V NiMh rechargeable battery and/or external charger.

The battery can be removed if it is not needed.

The 7660 circuit converts this voltage into a symmetrical +/-9V voltage needed by the instrumentation module.

The charging circuit: The voltage supplied via the 3.5mm plug is rectified and smoothed.

The lamp limits the charging current. The Z-diode limits the charging voltage.

On the vertical PC-board close to the front side are located:

The voltage divider resistors, the LED indicator, the on/off switch and the AC/DC coupling switch.

The LED serves as a battery check when the power is turned on. The longer the it flashes the higher is the charging status of the battery.

Specification:

Input Impedance:

4M Ω to ground – 8 M Ω differential

Input sensitivity:

500 V/div – 1V/div

Max input voltage:

800V to ground, 1500 V differential

Input load:

In all ranges up to the maximum input voltage

Input coupling: AC/DC

Common mode rejection: Typ 80dB

Bandwidth (-3dB):

Output cal @ 100mV/div: 50kHz

Output cal @ 1V/div: 10kHz

AC: lower frequency range starts from 5Hz

Output impedance: 1 k Ω /1nF

Output voltage Range: +/-6 V max.

Output calibration:

Jumper 2-3 (default) 100 mV/Div or 1Volt full scale.

Jumper 1-2 1 V/Div or 10 Volt (+/-5V) full scale.

Accuracy:

Std: 1% Ranges 1V-200V/Div, 1.5% @ 500V/Div.

Opt: 0.1% Ranges 1V-200V/Div, 0.2% @ 500V/Div.

Internal Battery:

9Volt NiMh rechargeable battery for 180 hours operation. Power and charging input:

12-24VDC or 9-18VAC

Power connector:

12VDC power jack with 2mm pin (0.08")

Operating temperature Range: -10/+70°C

Size: 165 x 130 x 42mm

Weight: 380 grams

The above data are valid in dry environment for the full operating temperature range.

GUARANTEE:

2 Years on material and working time excl. costs of transport. Excluded is damage caused by improper handling.