

SG-3013 Isolated RTD Input Module User's Manual

Introduction

The SG-3013 is a RTD input signal conditioning module to transform RTD input to voltage or current output. SG-3013 uses a microprocessor-based transducer, which integrating two high resolution ADCs and an MCU, to acquire the RTD signal. The supported RTD types are Pt100 , Pt1000 , Ni 120 , Cu100 ,and Cu1000.

The SG-3013 supports 3000Vdc isolation. The power supply that drives the module`s input and output circuitry is internally isolated, enabling SG-3013 to offer true channel - to - channel isolation.

It's easy to mount the SG-3013 on a standard DIN rail and can operate in environment with wide temperature range.

Specifications

Signal Input :

- **Input Type:** Pt100 $\alpha=0.00385$ / Pt100 $\alpha=0.003916$ / Ni 120 / Pt1000 $\alpha=0.00385$
- **RTD Type and Temperature Ranges:**

RTD Type	α	Temperature range(°C)
Pt100	0.00385	-200~600
Pt100	0.003916	-200~600
Pt1000	0.00385	-200~600
Ni 120		-80~300
Cu 100 at 0 °C	$\alpha= 0.00421$	-20~150
Cu 100 at 25 °C	$\alpha= 0.00427$	0~200
Cu 1000 at 0 °C	$\alpha= 0.00421$	-20~150

- **Input Connections:**2 / 3 / 4 wires

Voltage output:

- Unipolar: 0~5 V_{DC}, 0~10 V_{DC}
- Output impedance: < 50 Ω

Current output:

- Current: 0~20 mA, 4~20 mA
- Current load resistor:0~500 Ω (Source)

General

- Three-way isolation: 1000 V_{DC}
- Accuracy: ± 0.1 % of full range
- Operation temperature range:-25 °C~75 °C
- Storage temperature range:-30 °C~85 °C
- Weight: 94 gram

Supply Voltage

- Input Range: 10~30 V_{DC}
- Consumption: < 1.2 W

Configuration

The terminal wiring for the SG-3013 is shown in Figure A. The SG-3013 uses a power input range of 10~30 V_{DC}.

Table 1 and table 2 show the switch positions used to configure the input and output range.

The I/O configuration switches are located inside the module. And can be accessed by removing the DIN-rail bracket covers by sliding them in the direction shown in Figure B.

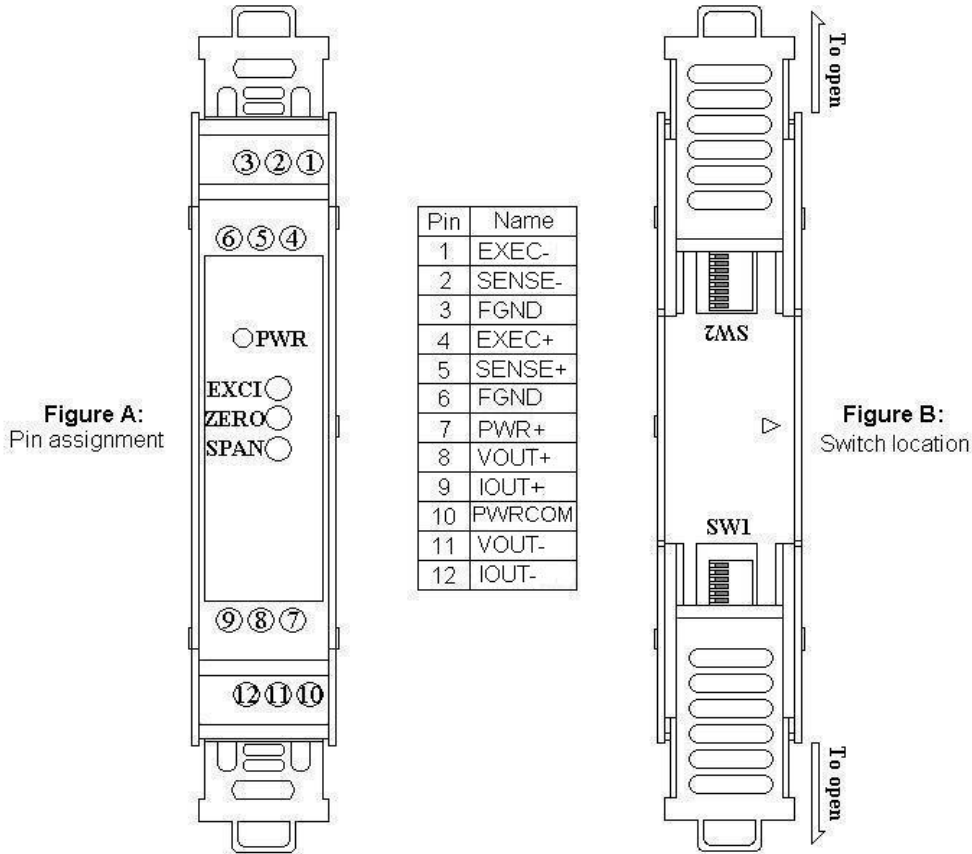

Switch Setting

SW1	Dip switch							
N.O	11111	11111	11111	11111	11111	11111	11111	11111
Function	2 ⁰	2 ¹	2 ²	2 ³	2 ⁴	2 ⁵	2 ⁶	+/-

Table 1: Offset setting (SW1)
◆offset: 0.1 °C

SW2	Dip switch							
N.O	1	2	3	4	5	6	7	8
Function	RTD Type Set					Open RTD	Current output	Voltage output
	2 ⁰	2 ¹	2 ²	2 ³	2 ⁴	0V/0mA 10V/20mA	0-20mA 4-20mA	10V 5V

Table 2: In/Output type setting (SW2)

RTD Type Setting table :

No	Switch		Temperature Range (°C)	RTD Type
1	0x00	00000	-200~200	Platinum 100, α = 0.00385
2	0x01	10000	-200~600	
3	0x02	01000	-100~100	
4	0x03	11000	-100~0	
5	0x04	00100	-100~200	
6	0x05	10100	-50~50	
7	0x06	01100	-50~150	
8	0x07	11100	0~100	
9	0x08	00010	0~200	
10	0x09	10010	0~600	
11	0X0A	01010	-200~200	Platinum 100, α = 0.003916
12	0X0B	11010	-200~600	
13	0X0C	00110	-100~100	
14	0X0D	10110	-100~0	
15	0X0E	01110	-100~200	
16	0X0F	11110	-50~50	
17	0x10	00001	-50~150	
18	0x11	10001	0~100	
19	0x12	01001	0~200	
20	0x13	11001	0~600	
21	0x14	00101	-200 ~ 600	Platinum 1000, α = 0.00385
22	0x15	10101	-80 ~ 100	Nickel 120
23	0x16	01101	0 ~ 100	
24	0x17	11101	0~300	
25	0x18	00011	-80~300	
26	0x19	10011	-20 ~ 150	Cu 100 at 0°C, α = 0.00421
27	0x1A	01011	0 ~ 200	Cu 100 at 25°C, α = 0.00427
28	0X1B	11011	-20 ~ 150	Cu 1000 at 0°C, α = 0.00421

Open RTD :

SW2-6 is determines output range of SG-3013 when RTD wiring open.

Current Output :

SW2-7 is determines current output range.

Voltage Output :

SW2-8 is determines Voltage output range.

Label :

SG3013 Configuration		SW2-6 Open RTD: <input type="checkbox"/> 0V/0mA <input checked="" type="checkbox"/> 10V/20mA	
		SW2-7 Current Output: <input type="checkbox"/> 0~20mA <input checked="" type="checkbox"/> 4~20mA	
		SW2-8 Voltage Output: <input type="checkbox"/> 0~10V <input checked="" type="checkbox"/> 0~5V	
Switch (SW) Setting: <input checked="" type="checkbox"/> ON <input type="checkbox"/> OFF			Temperature Offset Switch
RTD Type	Range(°C)	(SW2-) 1 2 3 4 5	(SW1-) 1 2 3 4 5 6 7 8 (°C)
Pt100 $\alpha = 0.00385$	-200~+200	<input type="checkbox"/> <input type="checkbox"/> <input type="checkbox"/> <input type="checkbox"/> <input type="checkbox"/>	<input checked="" type="checkbox"/> <input checked="" type="checkbox"/> <input checked="" type="checkbox"/> <input checked="" type="checkbox"/> <input checked="" type="checkbox"/> <input checked="" type="checkbox"/> <input checked="" type="checkbox"/> <input type="checkbox"/>
Pt100 $\alpha = 0.00385$	-200~+600	<input checked="" type="checkbox"/> <input type="checkbox"/> <input type="checkbox"/> <input type="checkbox"/> <input type="checkbox"/>	<input type="checkbox"/> <input checked="" type="checkbox"/> <input checked="" type="checkbox"/> <input checked="" type="checkbox"/> <input checked="" type="checkbox"/> <input checked="" type="checkbox"/> <input checked="" type="checkbox"/> <input type="checkbox"/>
⋮	⋮	⋮	⋮
Pt100 $\alpha = 0.003916$	0~+100	<input checked="" type="checkbox"/> <input type="checkbox"/> <input type="checkbox"/> <input type="checkbox"/> <input checked="" type="checkbox"/>	<input checked="" type="checkbox"/> <input type="checkbox"/> <input type="checkbox"/> <input type="checkbox"/> <input type="checkbox"/> <input type="checkbox"/> <input type="checkbox"/> <input type="checkbox"/>
Pt100 $\alpha = 0.003916$	0~+200	<input type="checkbox"/> <input checked="" type="checkbox"/> <input type="checkbox"/> <input type="checkbox"/> <input checked="" type="checkbox"/>	<input type="checkbox"/> <input type="checkbox"/> <input type="checkbox"/> <input type="checkbox"/> <input type="checkbox"/> <input type="checkbox"/> <input type="checkbox"/> <input type="checkbox"/>
Pt100 $\alpha = 0.003916$	0~+600	<input checked="" type="checkbox"/> <input checked="" type="checkbox"/> <input type="checkbox"/> <input type="checkbox"/> <input checked="" type="checkbox"/>	<input checked="" type="checkbox"/> <input type="checkbox"/> <input type="checkbox"/> <input type="checkbox"/> <input type="checkbox"/> <input type="checkbox"/> <input type="checkbox"/> <input checked="" type="checkbox"/>
Pt1000 $\alpha = 0.00385$	-200~+600	<input type="checkbox"/> <input type="checkbox"/> <input checked="" type="checkbox"/> <input type="checkbox"/> <input checked="" type="checkbox"/>	<input type="checkbox"/> <input checked="" type="checkbox"/> <input type="checkbox"/> <input type="checkbox"/> <input type="checkbox"/> <input type="checkbox"/> <input type="checkbox"/> <input checked="" type="checkbox"/>
Ni120	-80~+100	<input checked="" type="checkbox"/> <input type="checkbox"/> <input checked="" type="checkbox"/> <input type="checkbox"/> <input checked="" type="checkbox"/>	<input checked="" type="checkbox"/> <input checked="" type="checkbox"/> <input type="checkbox"/> <input type="checkbox"/> <input type="checkbox"/> <input type="checkbox"/> <input type="checkbox"/> <input checked="" type="checkbox"/>
Ni120	0~+100	<input type="checkbox"/> <input checked="" type="checkbox"/> <input checked="" type="checkbox"/> <input type="checkbox"/> <input checked="" type="checkbox"/>	<input type="checkbox"/> <input type="checkbox"/> <input checked="" type="checkbox"/> <input type="checkbox"/> <input type="checkbox"/> <input type="checkbox"/> <input type="checkbox"/> <input checked="" type="checkbox"/>
⋮	⋮	⋮	⋮
Cu100 $\alpha = 0.00427$	0~+200	<input type="checkbox"/> <input checked="" type="checkbox"/> <input type="checkbox"/> <input checked="" type="checkbox"/> <input checked="" type="checkbox"/>	<input type="checkbox"/> <input checked="" type="checkbox"/> <input checked="" type="checkbox"/> <input checked="" type="checkbox"/> <input checked="" type="checkbox"/> <input checked="" type="checkbox"/> <input checked="" type="checkbox"/> <input checked="" type="checkbox"/>
Cu1000 $\alpha = 0.00421$	-20~+150	<input checked="" type="checkbox"/> <input checked="" type="checkbox"/> <input type="checkbox"/> <input checked="" type="checkbox"/> <input checked="" type="checkbox"/>	<input checked="" type="checkbox"/> <input checked="" type="checkbox"/> <input checked="" type="checkbox"/> <input checked="" type="checkbox"/> <input checked="" type="checkbox"/> <input checked="" type="checkbox"/> <input checked="" type="checkbox"/> <input checked="" type="checkbox"/>
10 PWR COM	7 PWR+	6 FGND	3 FGND
11 VOUT-	8 VOUT+	5 SENSE+	2 SENSE-
12 IOUT-	9 IOUT+	4 EXC+	1 EXC-

Factory default setting :

SW1	Dip switch							
N.O	1	2	3	4	5	6	7	8
On/Off	<input type="checkbox"/>	<input type="checkbox"/>	<input type="checkbox"/>	<input type="checkbox"/>	<input type="checkbox"/>	<input type="checkbox"/>	<input type="checkbox"/>	<input type="checkbox"/>
Input	Pt100, $\alpha = 0.00385$, -200°C~+200°C							

SW2	Dip switch							
N.O	1	2	3	4	5	6	7	8
On/Off	<input type="checkbox"/>	<input type="checkbox"/>	<input type="checkbox"/>	<input type="checkbox"/>	<input type="checkbox"/>	<input type="checkbox"/>	<input checked="" type="checkbox"/>	<input type="checkbox"/>
Output	4~20 mA or 0~10 V							

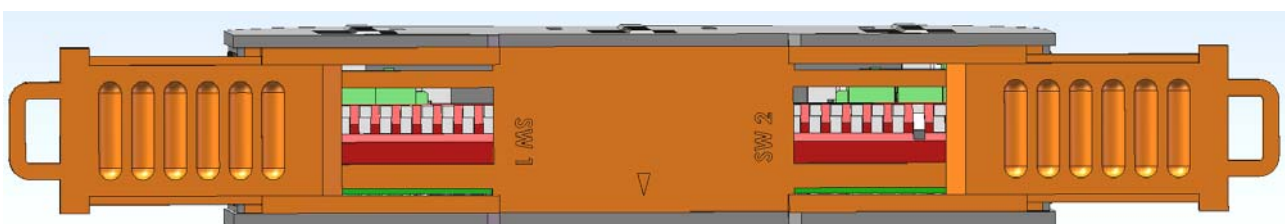

Wiring Diagram

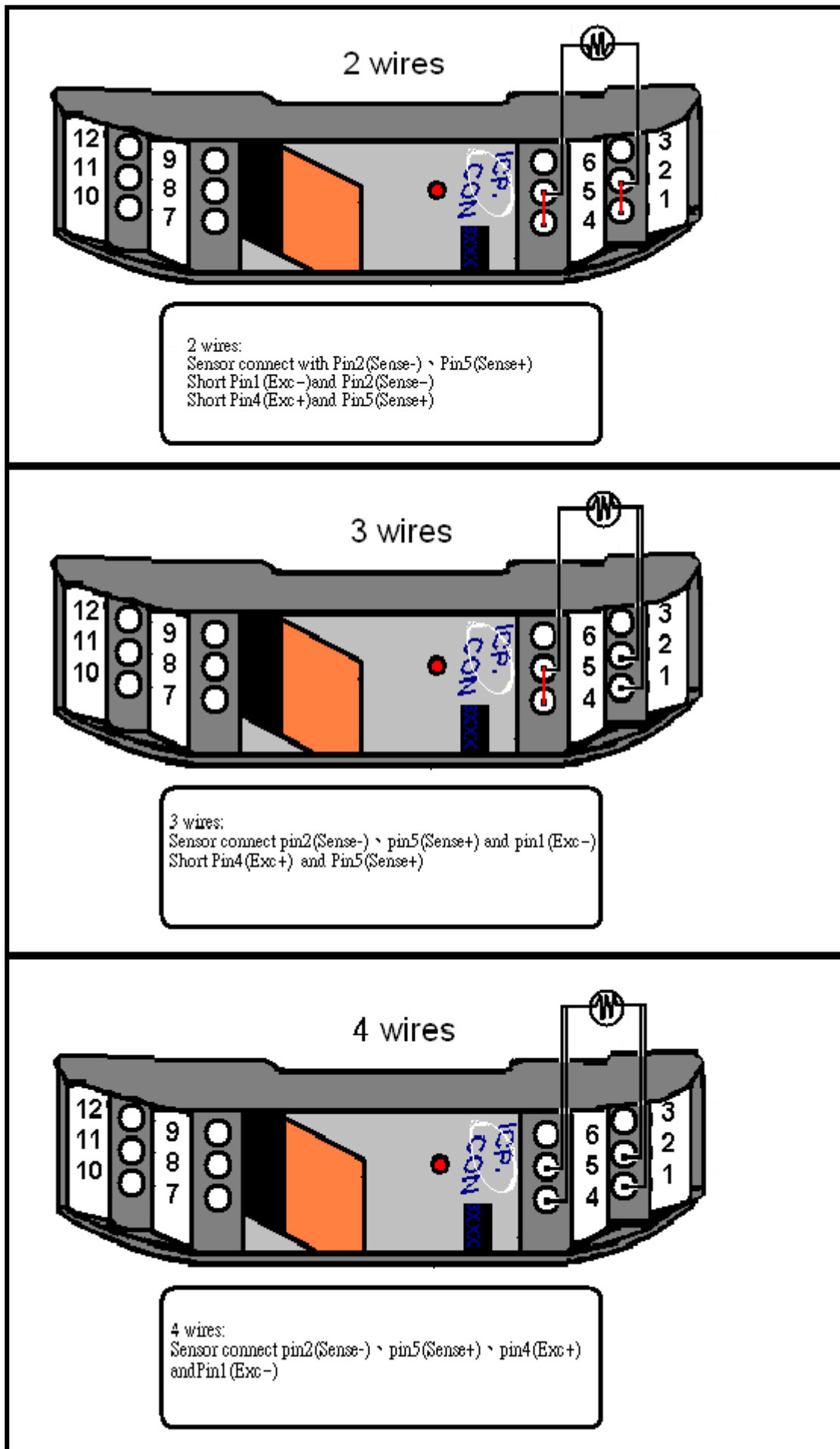

Block Diagram

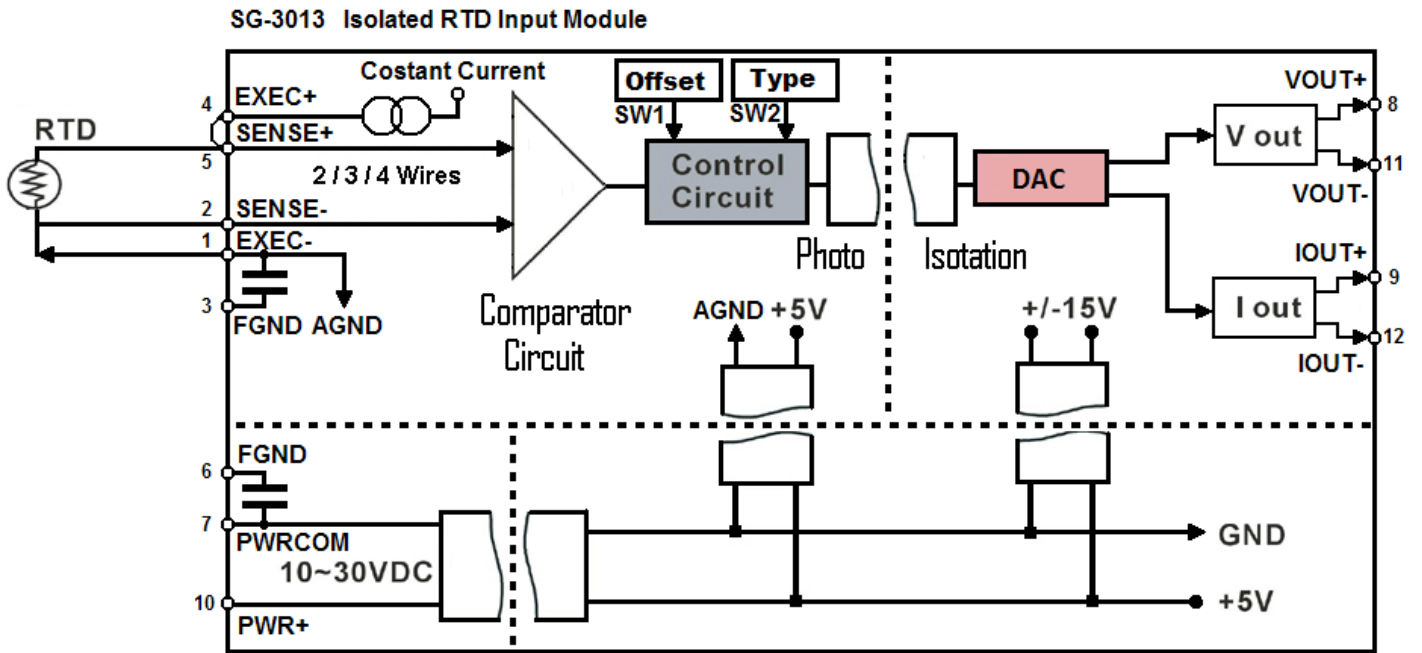

Dimensions

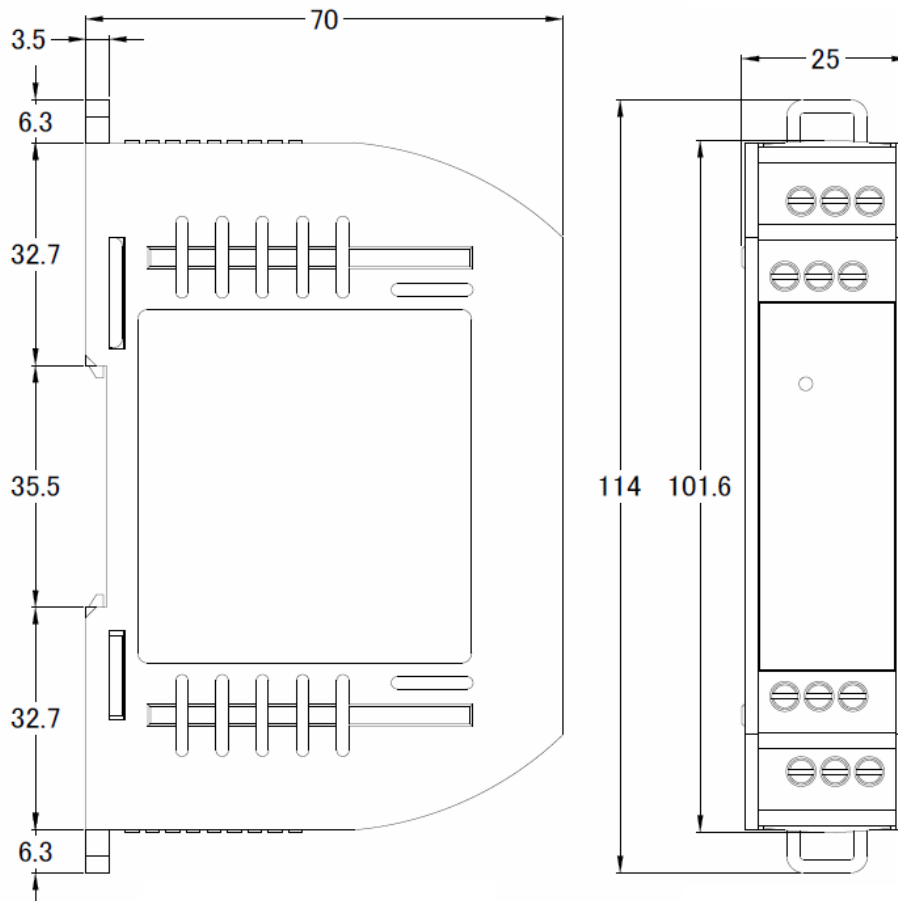

Technical Service:

Please E-mail your problem description to service@icpdas.com if you have any questions.

More detail information: <http://www.icpdas.com/>