

SG-3071 Isolated Voltage Input/Output Module

User's Manual

Introduction

The SG-3071 is a voltage input to voltage or current output signal conditioning module. It has 3000Vdc three-way isolation for input, output and power. And can change the input/output range via internal configuration switches.

The SG-3071 has an LED display to show whether the SG-3071 is functioning correctly and has two VRs (Zero, Span) to calibrate the input/output range accuracy.

The bandwidth of the SG-3071 is typically 3KHz. It's easy to mount the SG-3071 on a standard DIN rail and can operate in environments with wide temperature range.

Specifications

Voltage input:

- Bipolar: $\pm 5V$, $\pm 10V$
- Unipolar: 0~5V, 0~10V
- Input impedance: $2M\Omega$
- Input bandwidth: 3KHz (typical)@-3dB

Voltage output:

- Bipolar: $\pm 5V$, $\pm 10V$
- Drive: 10mA (max.)
- Output impedance: $<50\Omega$

Current Output:

- Current: 0 ~ 20mA, 4 ~ 20mA
- Current load resistor: 0~500 Ω (Source)

General

- Three-way isolation: 1000 Vdc
- Accuracy: $\pm 0.1\%$ of full range (typical)
- Operation temperature range: $-25^{\circ}C \sim 75^{\circ}C$
- Storage temperature range: $-30^{\circ}C \sim 85^{\circ}C$
- Operation bandwidth: 3KHz
- Weight: 94 gram

Supply Voltage

- Input Range: 10~30Vdc@24Vdc (Typical)
- Consumption: 1.80W (voltage output)
2.30W (current output)

Configuration

The terminal wiring for the SG-3071 is shown in Figure A. Positive power terminals pins 7 and 9 are internally connected, as are negative pins 10 and 12. Power can be connected through the adjacent modules, making wiring much easier. The SG-3071 uses a power input range of 10~30Vdc.

Table 1 shows the switch positions used to configure the input and output range. The I/O configuration switches are located inside the module. And can be accessed by removing the DIN-rail bracket covers by sliding them in the direction shown in Figure B.

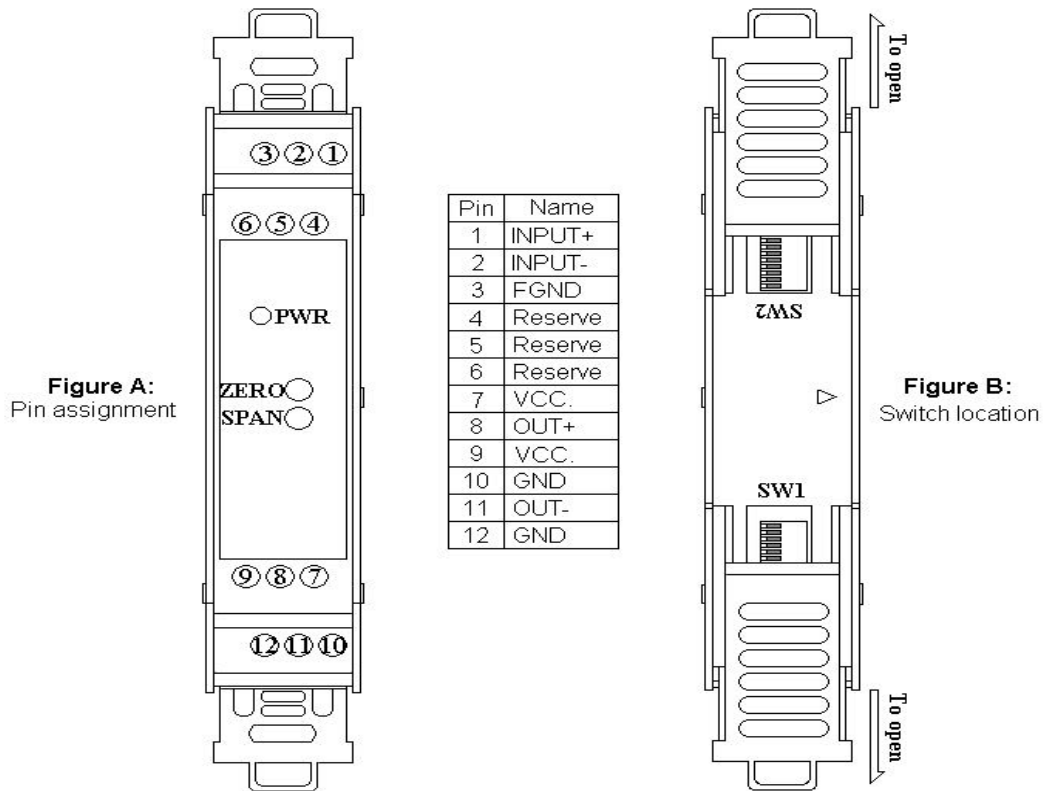

Figure A: Pin assignment

Figure B: Switch location

SG3071 Input To Output Range	Range (SW1)					Range (SW2)				
	1	2	3	4	5	1	2	3	4	5
±10V/±10V		◆	◆				◆			
±10V/±5V		◆	◆			◆				
* ±5V/±5V		◆	◆				◆			
±5V/±10V		◆	◆					◆		
0~10V/4~20mA	◆			◆	◆		◆		◆	
0~10V/0~20mA				◆	◆	◆				◆
0~5V/4~20mA	◆			◆	◆			◆	◆	
0~5V/0~20mA				◆	◆		◆			◆

◆ : ON

Table 1: Input to output range (SW1、2)

* Factory default setting

Calibration Procedure

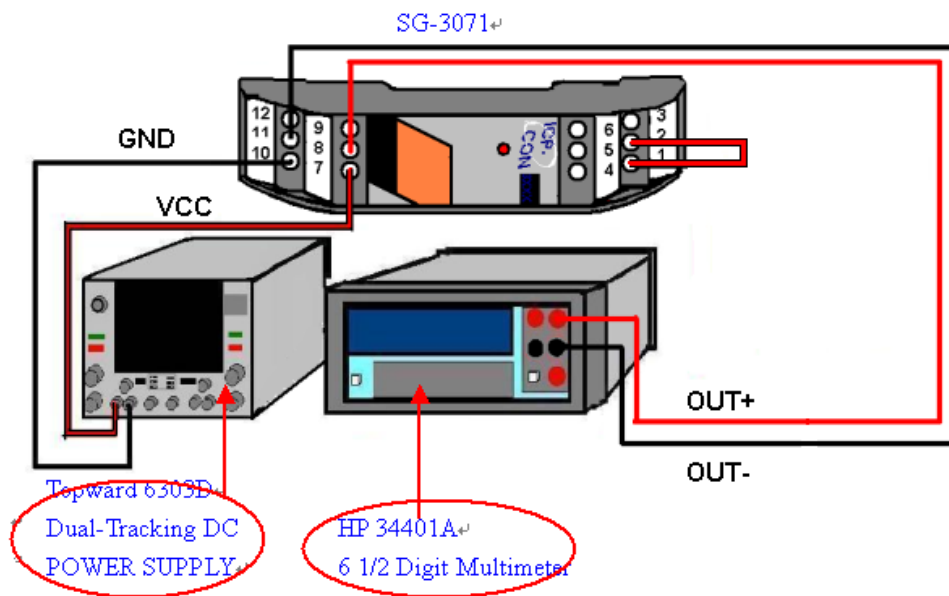

Figure C :
Offset Regulate

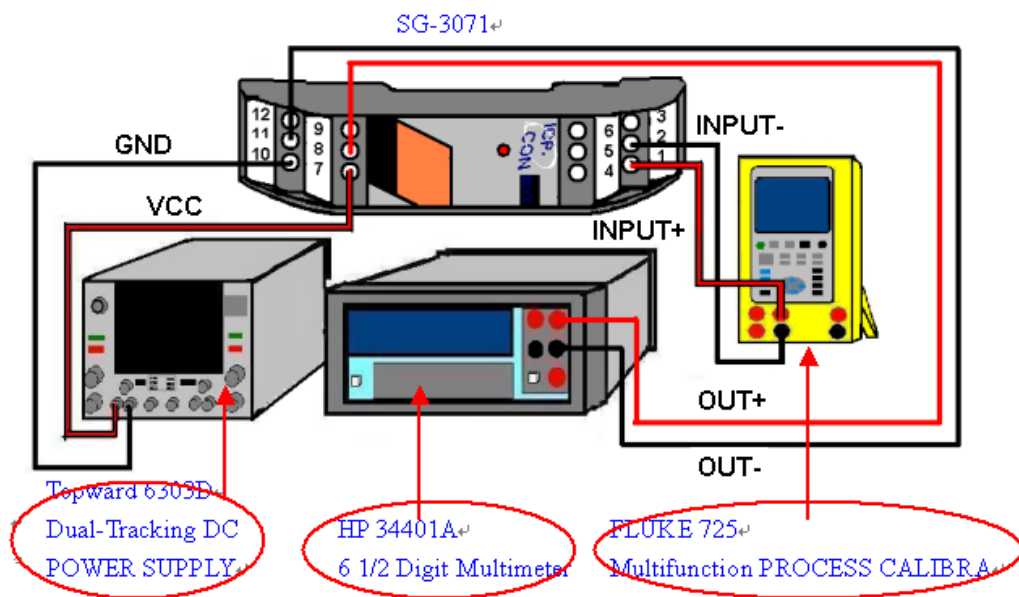

Figure D :
Gain Regulate

1. Refer to figure C to adjust the offset value.
 - (1) Connect pin7 to the +24Vdc connection and pin 10 to GND.
 - (2) Connect pin8 and pin 11 to the meter.
 - (3) Use wire to connect pins 1 and 2.
 - (4) Changing the SW1 and SW2 depends on your input/output range. Watch the value of the meter and adjust the VR1 (ZERO) value to the minimum value of this range.

2. Refer to figure D to adjust the gain value.

- (1) Connect pin7 to the +24Vdc connection and pin 10 to GND.
- (2) Connect pin8 and pin 11 to the meter.
- (3) Connect pins 1 and 2 to input source.
- (4) Changing the SW1 and SW2 depends on your Input/Output range. Watch the value of the meter and adjust the VR2 (SPAN) value to the maximum value of this range.

Block Diagram

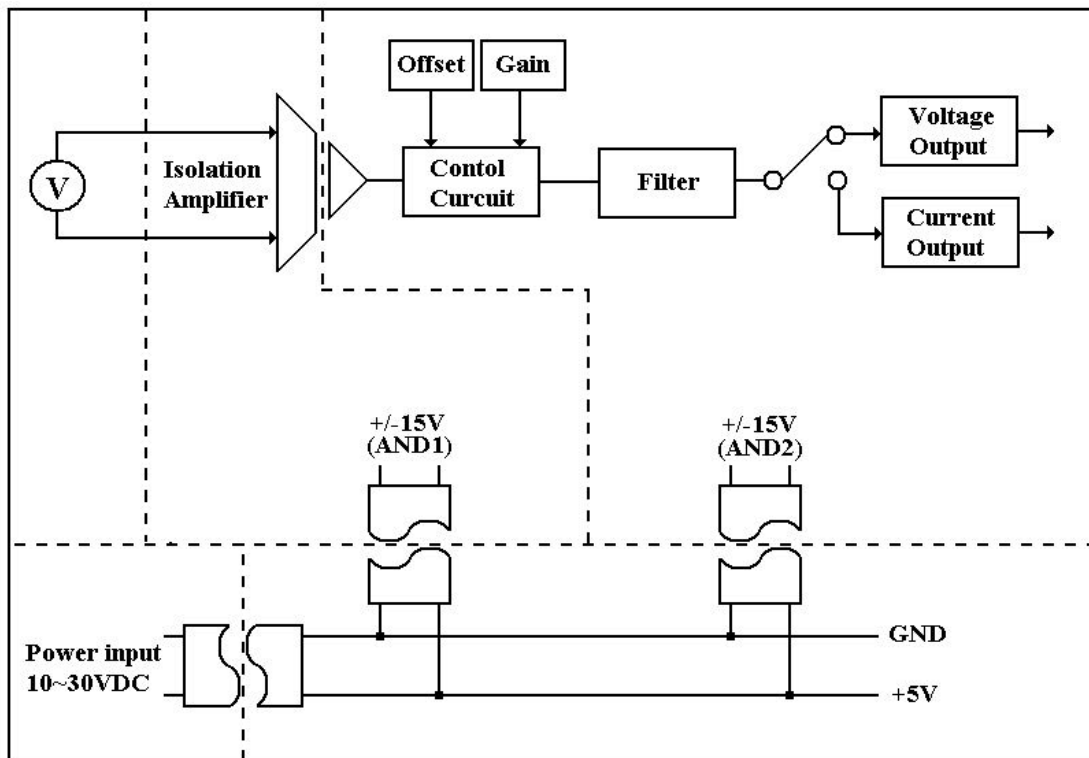

Dimensions

Units:mm

