

I-7018(R) M-7018(R)
8-channel Analog Input Module

Features

- I-7018
 - ±120 Vdc Overvoltage Protection
 - 8-channel Differential or 6-channel Differential and 2-channel Single-ended Analog Input
- I-7018R and M-7018R
 - Overvoltage Protection can be up to 240 Vrms
 - 8-channel Differential Analog Input
- Current, Voltage or Thermocouple Input
- 3000 Vdc Intra-module Isolation
- Dual Watchdog
- Wide Operating Temperature Range: -25 to +75°C



Introduction

The I-7018/M-7018 is an 8-channel Analog Input module that provides current and voltage input, as well as thermocouple input. The I-7018R/M-7018R is an upgraded version of the I-7018/M-7018 that includes an extremely high-quality protection mechanism where the overvoltage protection can be as high as 240 Vrms. The I-7018R/M-7018R is more suitable for critically harsh environments, and the newly-added open thermocouple detection feature makes the I-7018R/M-7018R more attractive than ever. The I-7018/M-7018/I-7018R/M-7018R also features 4 kV ESD protection and 3000 Vdc intra-module isolation. The specifications for the M-7018 and M-7018R are the same as the I-7018 and I-7018R, but provide additional support for the Modbus RTU protocol as well as the DCON protocol.

System Specifications

Model	I-7018	I-7018R	M-7018	M-7018R
Communication				
Interface	RS-485			
Bias Resistor	No (Usually supplied by the RS-485 Master. Alternatively, add a tM-SG4 or SG-785.)			
Format	(N, 8, 1) (N, 8, 2) (E, 8, 1) (O, 8, 1)			
Baud Rate	1200 to 115200 bps			
Protocol	DCON		Modbus RTU, DCON	
Dual Watchdog	Yes, Module (1.6 Seconds), Communication (Programmable)			
LED Indicators/Display				
System LED Indicator	Yes, 1 as Power/Communication Indicator			
I/O LED Indicators	-			
7-segment LED Display	-			
Isolation				
Intra-module Isolation, Field-to-Logic	3000 Vdc			
EMS Protection				
ESD (IEC 61000-4-2)	±4 kV Contact for each Terminal			
EFT (IEC 61000-4-4)	±4 kV to Power			
Surge (IEC 61000-4-5)	±0.5 kV for Power Line			
Power				
Reverse Polarity Protection	Yes			
Input Range	+10 ~ +30 Vdc			
Consumption	1.0 W			
Mechanical				
Dimensions (L x W x H)	123 mm x 72 mm x 35 mm			
Installation	DIN-Rail or Wall Mounting			
Environment				
Operating Temperature	-25 to +75°C			
Storage Temperature	-40 to +85°C			
Humidity	10 to 95% RH, Non-condensing			

Applications

- Building Automation
- Machine Automation
- Remote Diagnosis
- Factory Automation
- Remote Maintenance
- Testing Equipment

I/O Specifications

Model	I-7018	I-7018R	M-7018	M-7018R
Analog Input				
Channels	6 Differential and 2 Single-ended, or 8 Differential	8 Differential	6 Differential and 2 Single-ended, or 8 Differential	8 Differential
Wiring	Differential			
Sensor Types	Thermocouple	J, K, T, E, R, S, B, N, C		
	Voltage	±15 mV, ±50 mV, ±100 mV, ±500 mV, ±1 V, ±2.5 V		
	Current	±20 mA, 0 ~ +20 mA, +4 ~ +20 mA (requires an optional external 125 Ω resistor)		
Resolution	16-bit			
Accuracy	0.1% of FSR			
Sampling Rate	10 Hz (Total)			
Input Impedance	> 400 kΩ			
Common Voltage Protection	25 Vdc	200 Vdc	25 Vdc	200 Vdc
Individual Channel Configuration	-	Yes *Note2	-	Yes *Note3
Overvoltage Protection	±120 Vdc	240 Vrms	±120 Vdc	240 Vrms
Open Wire Detection (for thermocouple only)	-	Yes	-	Yes
Temperature Outputs Consistency	-			
Stable Temperature Output in the Field	-			

Note 1: For highly-accurate thermocouple measurement, ICP DAS recommends selecting the I-7018Z/I-7019Z module, which features automatic cold-junction compensation for each channel, ensuring consistent and stable temperature output.

Note 2: Firmware version B4.2 or later.

Note 3: Firmware version B4.5 or later.

Thermocouple Type

Type Code	Thermocouple Type	Temperature Range
0E	J	-210 to +760°C
0F	K	-270 to +1372°C
10	T	-270 to +400°C
11	E	-270 to +1000°C
12	R	0 to +1768°C
13	S	0 to +1768°C
14	B	0 to +1820°C
15	N	-270 to +1300°C
16	C	0 to +2320°C
17	L	-200 to +800°C
18	M	-200 to +100°C
19	L2DIN43710	-200 to +900°C

Internal I/O Structure

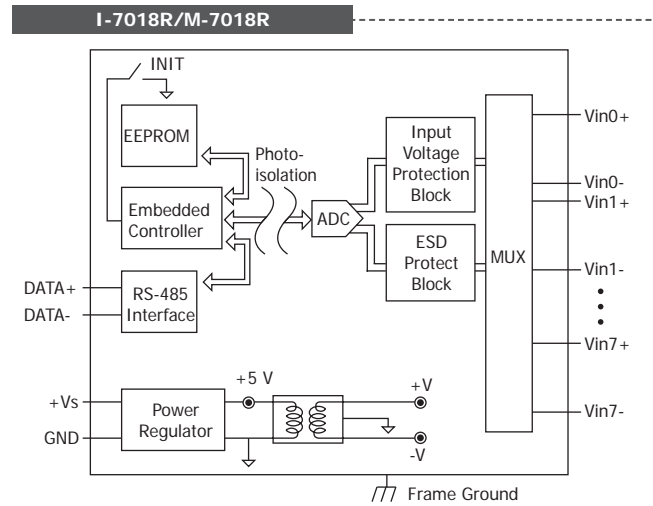
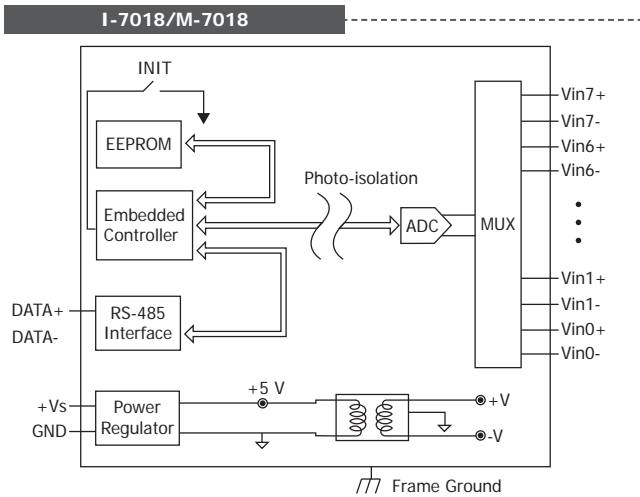

Pin Assignments

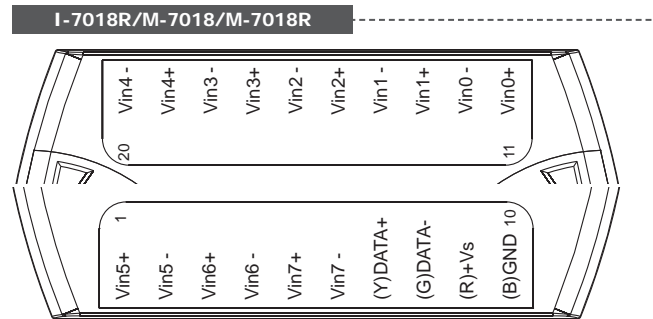
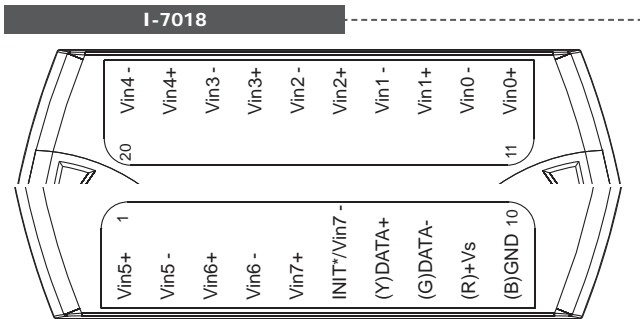

Wire Connections

I-7018/I-7018R/M-7018/M-7018R	
Analog Input Channels 0 to 5	
Requires an Optional External 125 Ω Resistor	
I-7018	
Analog Input Channels 6 and 7	
8-channel Differential Mode JP1: ● ● ● ● 	INIT* Mode JP1: ● ● ● ●
Requires an Optional External 125 Ω Resistor	

Note: To access the jumpers, the cover must be opened.

Ordering Information

I-7018 CR	8-channel Analog Input Module using the DCON Protocol (Blue Cover) (RoHS)
I-7018-G CR	8-channel Analog Input Module using the DCON Protocol (Gray Cover) (RoHS)
I-7018R CR	8-channel Analog Input Module using the DCON Protocol with High Voltage Protection (Blue Cover) (RoHS)
I-7018R-G CR	8-channel Analog Input Module using the DCON Protocol with High Voltage Protection (Gray Cover) (RoHS)
M-7018-G CR	8-channel Analog Input Module using the DCON and Modbus Protocols (Gray Cover) (RoHS)
M-7018R-G CR	8-channel Analog Input Module using the DCON and Modbus Protocols with High Voltage Protection (Gray Cover) (RoHS)

Accessories

	tM-7520U CR	RS-232 to RS-485 Converter (RoHS)
	tM-7561 CR	USB to RS-485 Converter (RoHS)
	tM-SG4 CR	RS-485 Bias and Termination Resistor Module (RoHS)
	I-7514U CR	4-channel RS-485 Hub (RoHS)
	SG-770 CR	7-channel Differential or 14-channel Single-ended Surge Protector (RoHS)
	SG-3000 Series	Signal Conditioning Modules for Thermocouple, RTD, DC Voltage, DC Current and Power Input Transformers
	125 Ω, 0.1% DIP Resistor	125 Ω External Resistor for use with Current input on I-7011/I-7012/I-7017/I-7018 series modules

2
3

RS-485 Remote I/O Modules

I-7018/I-7018R/M-7018/M-7018R