



M-7041-A5

M-7041D-A5

14-channel High Voltage Isolated Digital Input Module

Features

- 150 V High Voltage Digital Inputs
- Sink- or Source-type Digital Inputs
- Photocouple Isolation
- All Channels Can Be Used As 16-bit Counters
- ±4 kV ESD Protection
- 3750 Vdc Isolation Voltage
- Built-in Dual Watchdog
- Wide Operating Temperature Range: -25 to +75°C



Introduction

The M-7041(D)-A5 provides 14 channels for high voltage digital input, each of which features photocouple isolation. The input voltage level could be as high as 150V. In addition, either sink- or source-type digital input can be selected via wire connections, and all channels are able to be used as 16-bit counters. The M-7041D-A5 has 14 LED indicators for DI channel status monitoring. 4 kV ESD protection and 3750 Vdc intra-module isolation are standard. The M-7041(D)-A5 support both the Modbus RTU and DCON protocols, which can be configured via software.

Applications

- All Types of On/Off Control
- Industrial Automation
- Industrial Machinery
- Building Automation
- Food and Beverage Systems
- Semiconductor Fabrication
- Control Systems

System Specifications

Model	M-7041-A5	M-7041D-A5
Communication		
Interface	RS-485	
Bias Resistor	No (Usually supplied by the RS-485 Master. Alternatively, add a tM-SG4 or SG-785.)	
Format	N, 8, 1	
Baud Rate	1200 to 115200 bps	
Protocol	DCON	Modbus RTU, DCON
Dual Watchdog	Yes, Module (1.6 Seconds), Communication (Programmable)	
LED Indicators/Display		
System LED Indicator	Yes, 1 as Power/Communication Indicator	
I/O LED Indicators	-	Yes, 14 LEDs as Digital Input Indicators
7-segment LED Display	-	
Isolation		
Intra-module Isolation, Field-to-Logic	3750 Vdc	
EMS Protection		
ESD (IEC 61000-4-2)	±4 kV Contact for each Terminal	
	±8 kV Air for Random Point	
EFT (IEC 61000-4-4)	±4 kV, ±2 kV for the RS-485 Port	
Surge (IEC 61000-4-5)	-	
Power		
Reverse Polarity Protection	Yes	
Input Range	+10 ~ +30 Vdc	
Consumption	0.2 W	1.0 W
Mechanical		
Dimensions (L x W x H)	123 mm x 72 mm x 35 mm	
Installation	DIN-Rail or Wall Mounting	
Environment		
Operating Temperature	-25 to +75°C	
Storage Temperature	-40 to +85°C	
Humidity	10 to 95% RH, Non-condensing	

I/O Specifications

Model	M-7041-A5	M-7041D-A5
Digital Input/Counter		
Channels	14	
Type	Dry Contact	-
	Wet Contact	Sink/Source
Wet Contact	ON Voltage Level	+68 ~ +150 Vdc
	OFF Voltage Level	+48 Vdc Max.
Dry Contact	ON Voltage Level	-
	OFF Voltage Level	-
Counters	Effective Distance for Dry Contact	-
	Max. Count	65535 (16-bit)
	Max. Input Frequency	100 Hz
	Min. Pulse Width	5 ms
Input Impedance	50 kΩ	
Channel-to-Channel Isolation	-	
Overvoltage Protection	-	

Internal I/O Structure

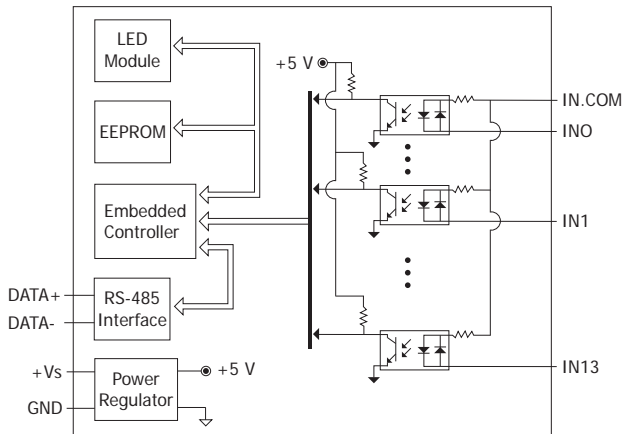

Pin Assignments

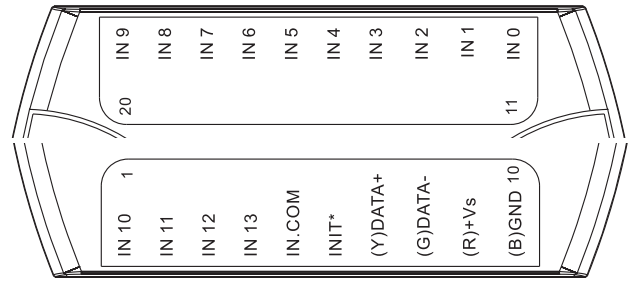

Wire Connections

Digital Input/Counter	ON State Readback as 1 +68 ~ +150 VDC	OFF State Readback as 0 OPEN or <48 VDC
Sink		
Source		

Ordering Information

M-7041-A5-G CR	14-channel High Voltage Isolated Digital Input Module using the DCON and Modbus Protocols (Gray Cover) (RoHS)
M-7041D-A5-G CR	M-7041-A5 with LED Display (Gray Cover) (RoHS)

Accessories

	tM-7520U CR	RS-232 to RS-485 Converter (RoHS)
	tM-7561 CR	USB to RS-485 Converter (RoHS)
	tM-SG4 CR	RS-485 Bias and Termination Resistor Module (RoHS)
	I-7514U CR	4-channel RS-485 Hub (RoHS)
	SG-770 CR	7-channel Differential or 14-channel Single-ended Surge Protector (RoHS)
	SG-3000 Series	Signal Conditioning Modules for Thermocouple, RTD, DC Voltage, DC Current and Power Input Transformers